

# FLOJET®



## Flojet Bottled Water System *Plus* FOR HOME AND COMMERCIAL APPLIANCES

*The Bottled Water System Plus is part of Flojet's premium water dispensing product line.*

When a water bottle is connected to the system, fresh water is available for use with coffee/tea machines, water dispensers, refrigerators, ice makers, or any other application where portable potable water is needed.

The Bottled Water System Plus is also designed for convenience—the pump shuts off when the water source is depleted, and when water is restored, the pump will automatically restart. This eliminates the chance of any damage to the appliance running dry.

### **Features and Benefits**

- For home or commercial applications
- Easy and quick installation and maintenance
- Built-in check valve prevents back flow
- Float switch for automatic shut-off
- No need for water filters
- Illuminated ON/OFF Switch
- Quick disconnect ports
- Quiet operation



*Engineered for life*

# BOTTLED WATER SYSTEM PLUS | FOR HOME AND COMMERCIAL APPLIANCES

## Applications

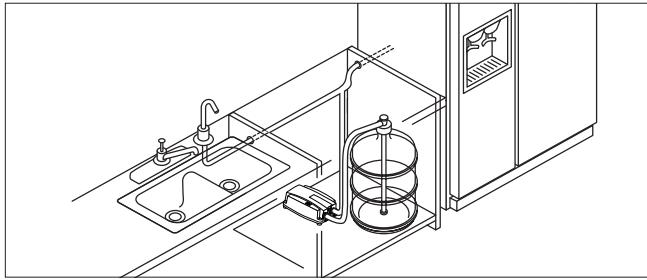

Refrigerator Dispense

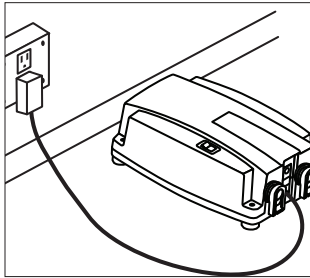

Universal Wall Transformer

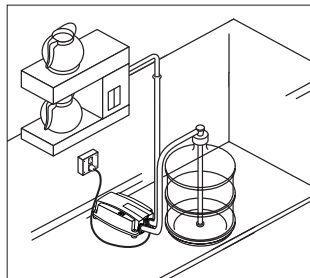

Coffee Maker Dispense

## Dimensional Drawing

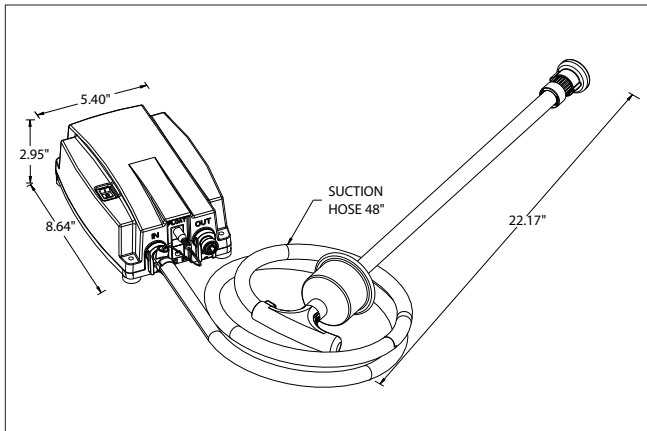

## Specifications

Flow Rate	1.09 GPM (3.875 LPM)
Max Pressure	40 PSI (2.76 BAR)
Dimensions	2.7"H x 5.4"W x 8.5"D (6.86H cm x 13.72W cm x 21.60D cm)
Voltage VAC	115, 230
Amp Draw	230 VAC, 0.3 Amp Max 115 VAC, 0.5 Amp Max
Cycles	AC 50/60 Hz
Weight	4.5 lbs (2.04 kg)

## Kit Includes

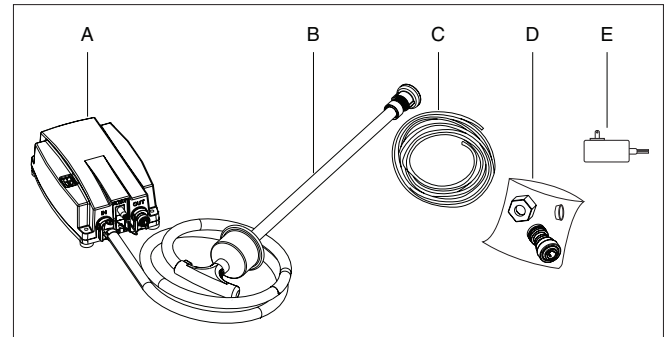

- A. Pump Module with On/Off Rocker Switch, 3.5 ft. (1m) Cord.
- B. Suction Wand and Hose Assembly
- C. 20 ft (6.1m) of 1/4 in. (6.35mm) Discharge Tube
- D. Kit Fitting: Hose port/connector, compression nut and sleeve.
- E. Universal wall transformer.

Model Number	Voltage	Flow Rate	Max Pressure
BW4000-000A	115 VAC	1.09 GPM (3.875 LPM)	40 PSI (2.76 BAR)
BW4003-000A	230 VAC	1.09 GPM (3.875 LPM)	40 PSI (2.76 BAR)



**P.G. Philippou & Sons Ltd**  
45E Griva Digeni Avenue  
P.O.Box 23447  
Cy-1683 Nicosia

Tel: +357 22666452  
Fax: +357 22668613  
E-mail: athosph@noricum.com.cy  
Web: www.thebbqstore.com.cy



Warranty: All products of the company are sold and all services of the company are offered subject to the company's warranty and terms and conditions of sale, copies of which will be furnished upon request. The information provided herein is for guidance only, it does not constitute a guarantee of the performance or specification of any individual product or component.