



## Assembly and Operating Instructions for Excel 100, Excel 200, and Excel 300 Gas Barbecues

EN (Europe)



Excel 100



Excel 200



Excel 300

Photographs are not to scale.  
Specifications subject to change  
without prior notice.



0359



### WARNING

- For outdoor use only. Not for commercial use.
- Read instructions before using the appliance. Failure to follow instructions could result in death, serious bodily injury, and/or property loss.
- Warning: accessible parts may be very hot. Keep young children away.
- Do not move the appliance during use.
- Turn off the gas supply at the gas bottle after use.
- Any modification of the appliance, misuse, or failure to follow the instructions may be dangerous and will invalidate your warranty. This does not affect your statutory rights.
- Retain these instructions for future reference.
- Leak test your barbecue annually. Check the hose connections are tight and leak test them each time you reconnect the gas bottle.
- For Flare-up control please refer to the 'OPERATION' section of this manual.

### FOR YOUR SAFETY

If you smell gas:

1. Shut off gas to the appliance.
2. Extinguish any open flame.
3. Open barbecue lid or hood.
4. If odour continues, discontinue use and contact your local dealer.

### FOR YOUR SAFETY

1. Do not store or use petrol or other flammable vapours or liquids in the vicinity of this or any other appliance.
2. A gas bottle not connected for use shall not be stored in the vicinity of this or any other appliance.

## A. Parts List

Quantities vary according to model purchased. Specifications subject to change without prior notice. For more details on hardware, please see the corresponding Hardware Reference Diagram for your barbecue model.

	CODE	PART	QTY	OUTBACK® EXCEL RANGE		
				EXCEL 100	EXCEL 200	EXEL 300
Body Assembly	A1	Lava Rock Rack	1	√	√	√
	A2	Burner	1	√	√	√
	A3	Hood Lower Handle	1	√	√	√
	A4	Hood	1	√*	√*	√*
	A5	Body	1	√*	√*	√*
	A6	Grease Cup Holder	1	√	√	√
	A7	Grease Cup	1	√	√	√
	A8	Cooking Grill	1	√	√	√
	A9	Lava Rock (Shrink Packed)	1	√*	√*	√*
	A10	Hood Upper Handle	1	√*	√*	√*
	A11	Hinge Bracket	2	√*	√*	√*
	A12	Main Electrode	1	√*	√*	√*
	A13	Heat Shield	1	√	√	√
	A14	Warming Rack	1	√	√	√
	A15	Sillon Bumpers	2	√	√	√
	A16	Body Support	2	√	√	√
Upper Trolley	B1	Control Panel	1	√	√	√
	B2	Igniter Button	1	√*	√*	√*
	B3	Main Burner Knob	2	√*	√*	√*
	B4	Trolley Handle	1	√		
	B5	Main Burner Hose (if supplied)	▲			
	B6	Side Shelf	▲		2	1
	B7	Side Burner Knob	1			√
	B8	Side Burner Grid	1			√
	B9	Side Burner Shelf	1			√
	B10	Side Burner	1			√
	B11	Side Burner Electrode	1			√
	B12	Side Burner Valve/Hose Assembly	1			√
Lower Trolley	C1	Short Leg Front	1	√	√	√
	C2	Short Leg Rear	1	√	√	√
	C3	Gas Cylinder Holder	1	√	√	√
	C4	Wheel	2	√	√	√
	C5	Axle	1	√	√	√
	C6	Leg End Loop	1	√	√	√
	C7	Long Leg Front	1	√	√	√
	C8	Long Leg Rear	1	√	√	√
	C9	Bottom Shelf	1	√	√	√
	C10	Gas Bottle Strap	1	√*	√*	√*
Hardware	D1	M6x15 Bolt	▲	24	28	28
	D2	M5x10 Bolt	4	√	√	√
	D3	M4x10 Bolt	1			√
	D4	ST4.0x10 Screw	2	√	√	√
	D5	ST4.8x15 Screw	2	√	√	√
	D6	M8 Locknut	2	√	√	√
	D7	M5 Keps Nut	2	√	√	√
	D8	Wheel Spacer	2	√	√	√
	D9	Shelf Spacer	▲		8	4

★ Pre-Assembled

▲ Quantity and specification varies according to model purchased.

## B1. Parts Diagram: Excel 100

Quantities vary according to model purchased. Specifications subject to change without prior notice. For more details on hardware, please see 'Hardware Reference Diagram: Excel 100.'

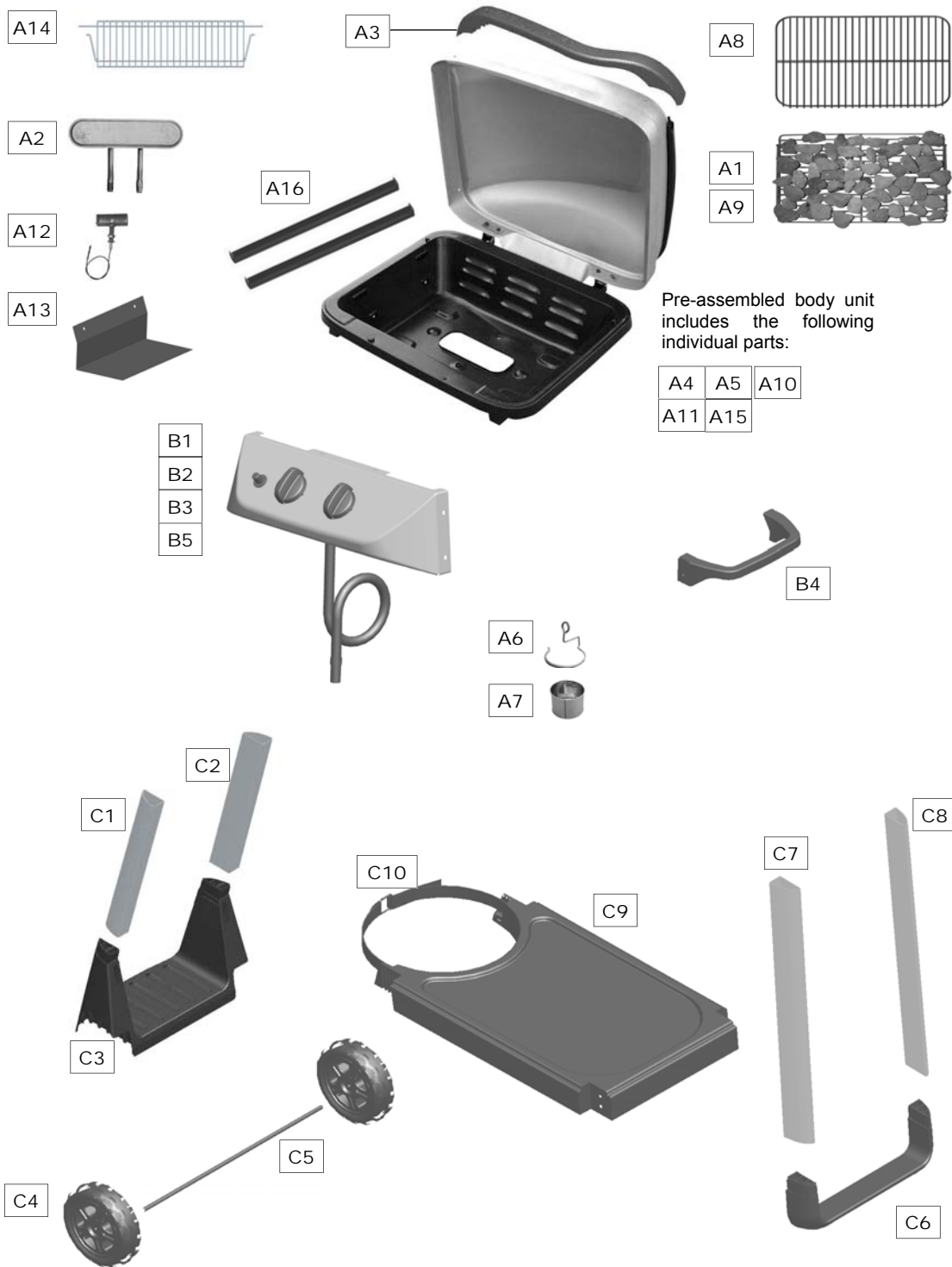

## **B2. Hardware Reference Diagram: Excel 100**

Specifications subject to change without prior notice.

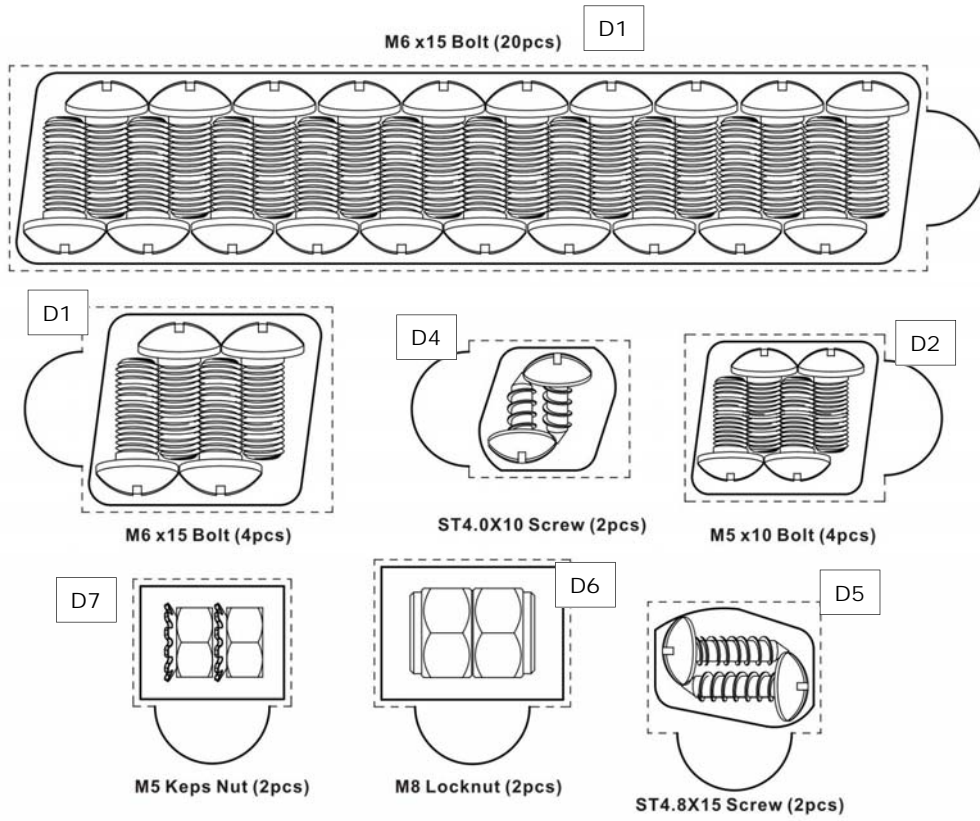

## C1. Parts Diagram: Excel 200

Quantities vary according to model purchased. Specifications subject to change without prior notice. For more details on hardware, please see 'Hardware Reference Diagram: Excel 200.'

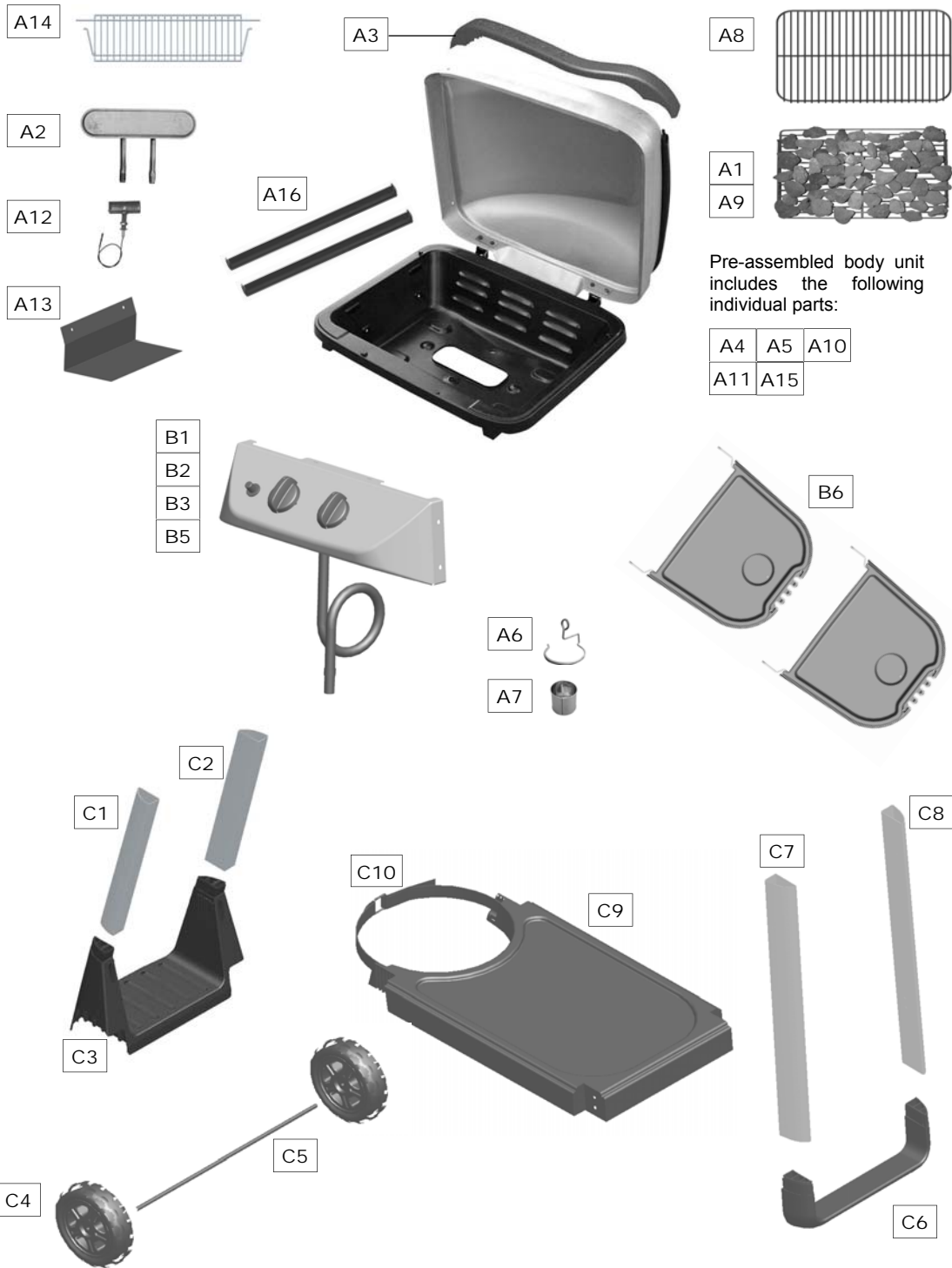

## **C2. Hardware Reference Diagram: Excel 200**

Specifications subject to change without prior notice.

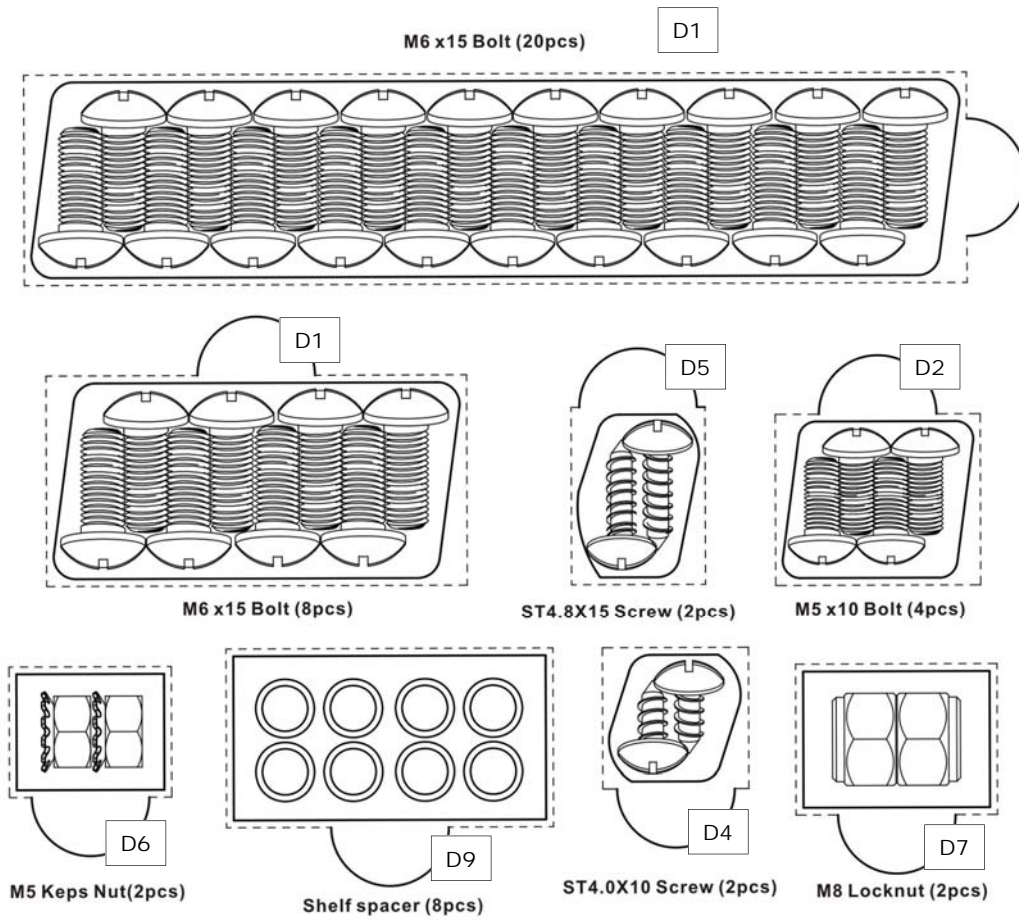

## D1. Parts Diagram: Excel 300

Quantities vary according to model purchased. Specifications subject to change without prior notice. For more details on hardware, please see 'Hardware Reference Diagram: Excel 300.'

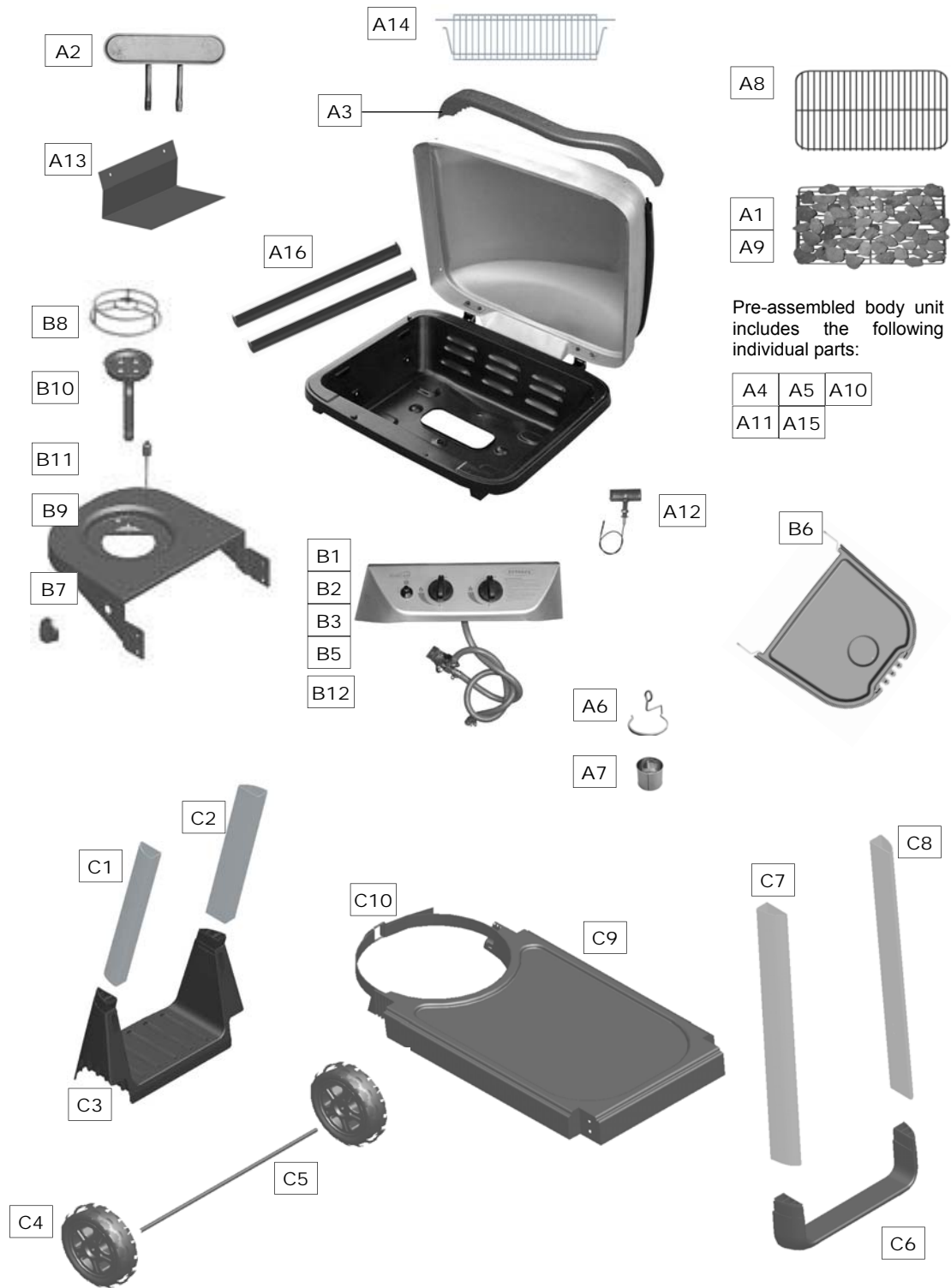

## **D2. Hardware Reference Diagram: Excel 300**

Specifications subject to change without prior notice.

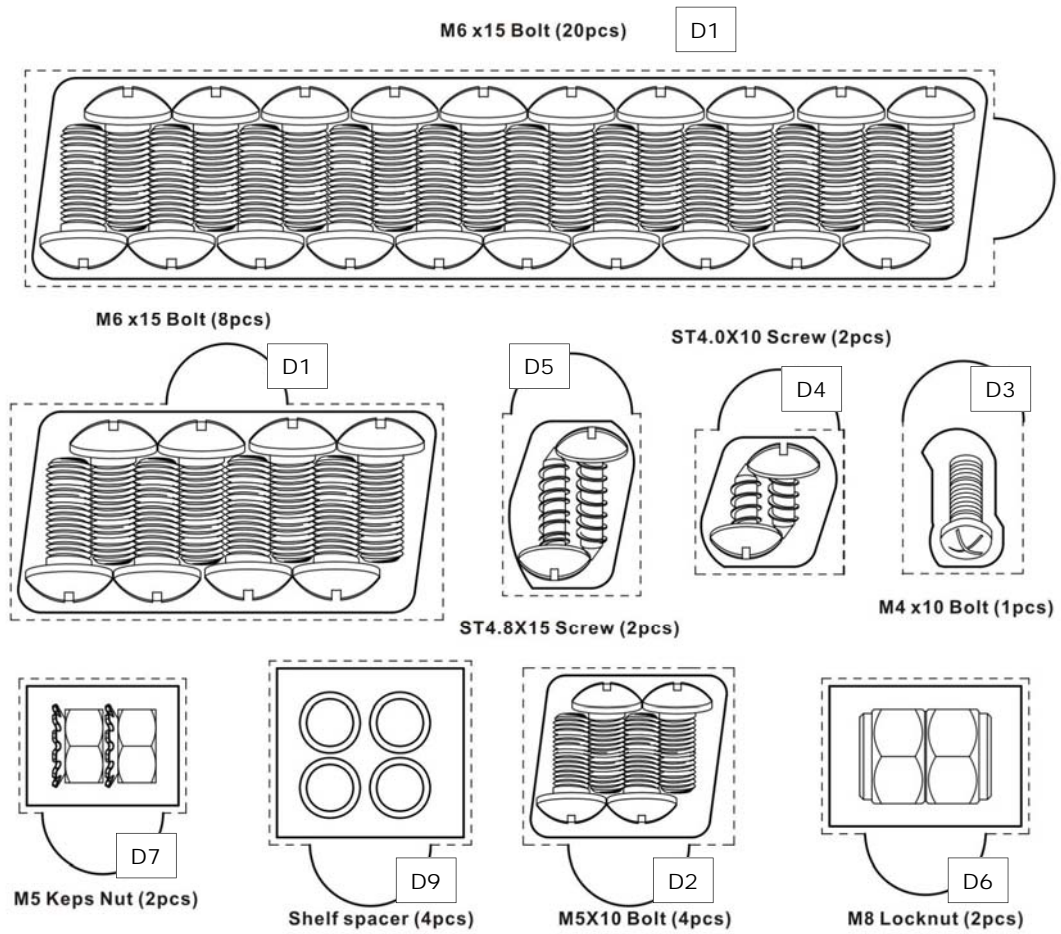



## **E. Assembly**

### **TOOLS NEEDED FOR ASSEMBLY:**

Medium size flat blade or Philips/cross-point screwdriver, adjustable spanner or metric spanner set

This barbecue requires two people for assembly. Please remove all packaging materials from all individual parts before assembling. Please lay out all nuts and bolts and check lengths before assembling. Whilst every care is taken during the manufacture of this product, care must be taken during the assembly in case sharp edges are present.

**1**

✓ Excel 100

✓ Excel 200

✓ Excel 300

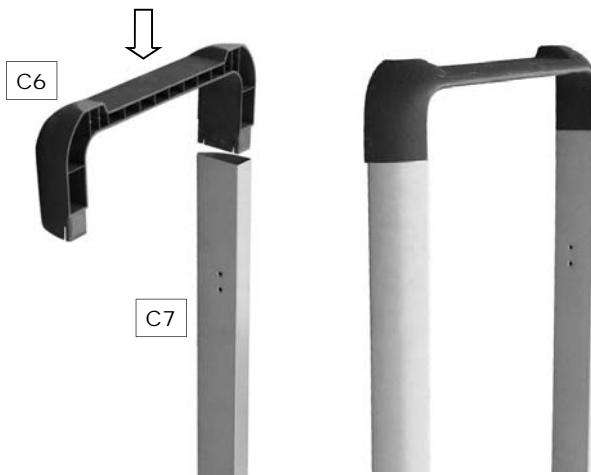

Attach the Long Leg Front (C7) and Long Leg Rear (C8) to the Leg End Loop (C6). The legs are a push fit onto the Leg End Loop. In case of difficulty, they may need tapping with a soft faced mallet. Take care not to damage the parts.

**2**

✓ Excel 100

✓ Excel 200

✓ Excel 300

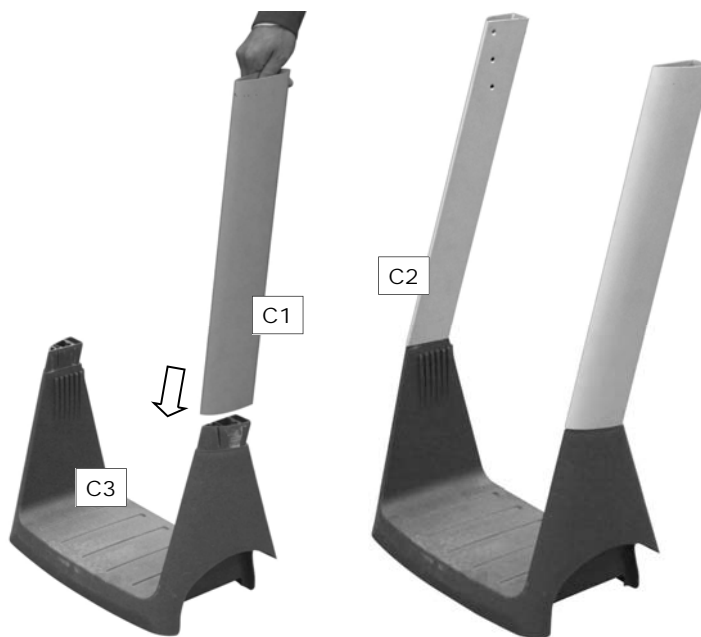

Attach the Short Leg Front (C1) and Short Leg Rear (C2) to the Gas Cylinder Holder (C3). The legs are a push fit onto the Gas Cylinder Holder. In case of difficulty; they may need tapping with a soft faced mallet. Take care not to damage the parts.

**3**

✓ Excel 100

✓ Excel 200

✓ Excel 300

Attach the Bottom Shelf (C9) to the Gas Bottle Holder (C3) using the screws (D5). Taking care not to over tighten.

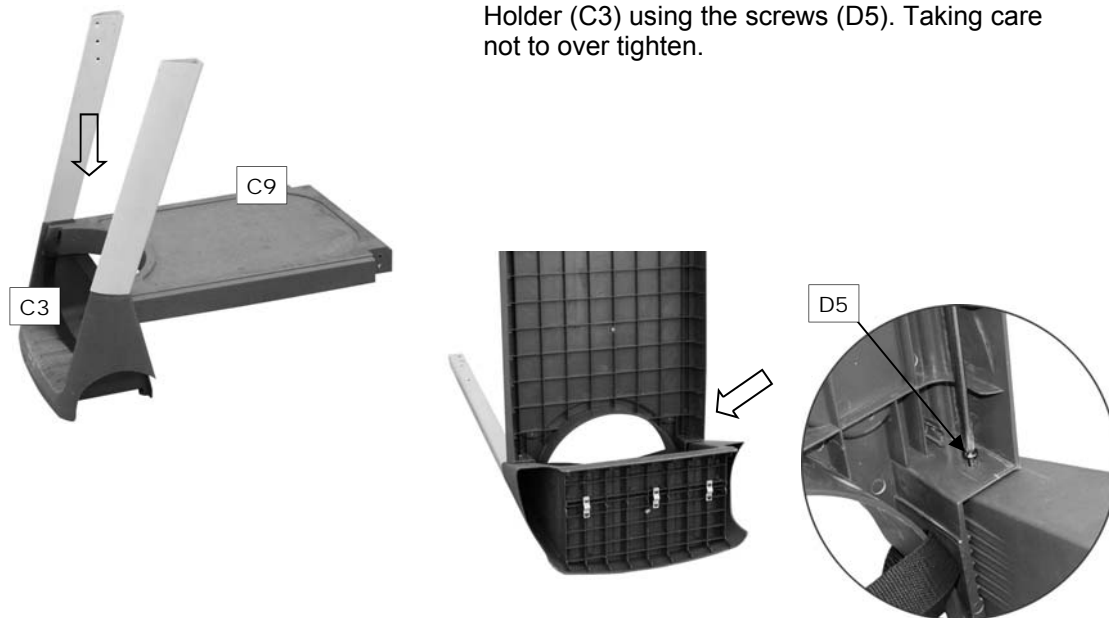

**4**

✓ Excel 100

✓ Excel 200

✓ Excel 300

Attach the leg assembly to the Bottom Shelf assembly using the screws (D1).

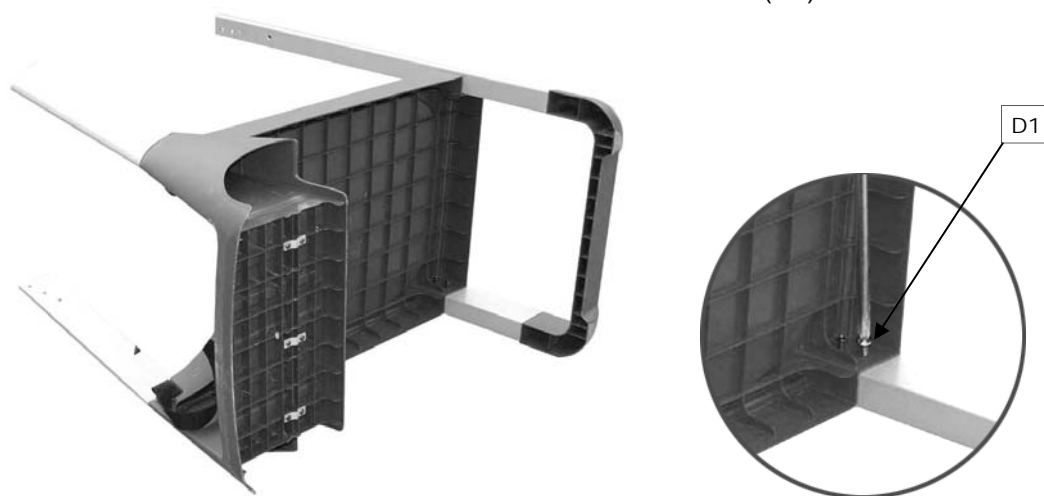

5

✓ Excel 100

✓ Excel 200

✓ Excel 300

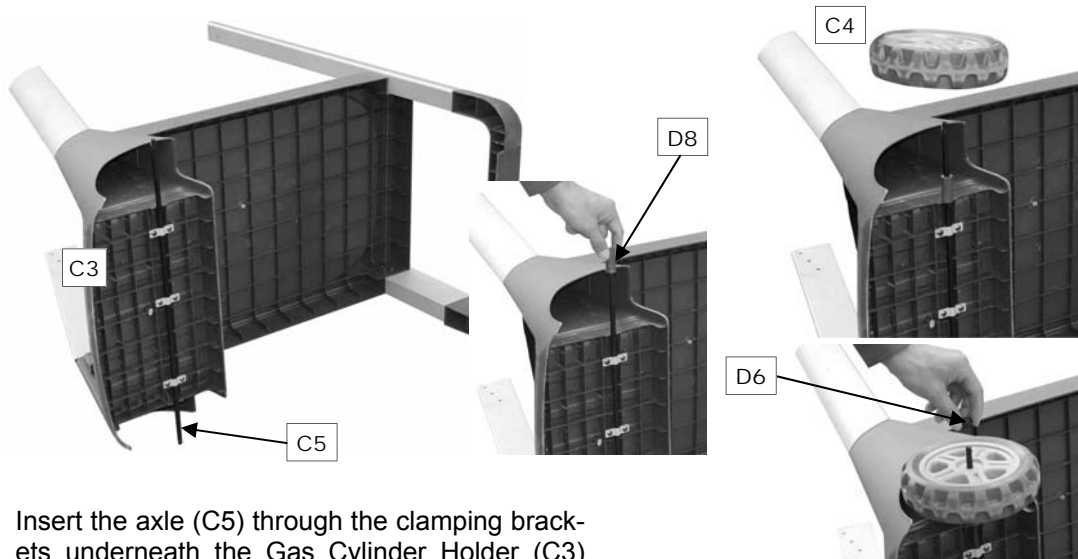

Insert the axle (C5) through the clamping brackets underneath the Gas Cylinder Holder (C3) and tighten the clamping screws. Taking care not to over tighten.

Slide a Wheel Spacer (D8) over the Axle (C5).

Slide a wheel (C4) and secure it with a M8 Locknut (D6). Repeat for the other side before standing it up.

6

✓ Excel 100

✓ Excel 200

✓ Excel 300

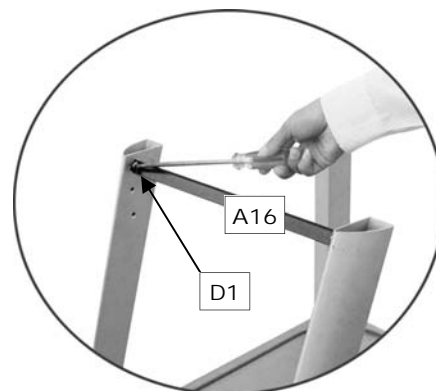

Attach the Body Support (A16) to the legs using the screws (D1).

Note: The notches on these supports should be outside in order to attach the body easily.

7

✓ Excel 100

✓ Excel 200

✓ Excel 300

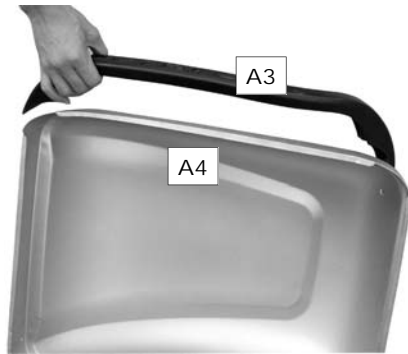

Attach the Hood Lower Handle (A3) to the Hood (A4) using the Screws (D2).

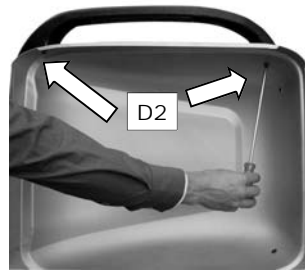

8

✓ Excel 100

✓ Excel 200

✓ Excel 300



Attach the Body (A5) to the Trolley Assembly using the Screws (D1). Ensure the tabs on the body fit over the legs as shown in the diagram and do not go down inside of the legs.

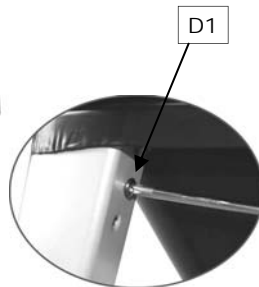

9

✓ Excel 100

✓ Excel 200

✓ Excel 300



Attach the Control Panel Assembly to the Trolley Assembly using the Screws (D1). Ensure the tabs on the body fit over the legs as shown in the diagram and do not go down inside of the legs.

10

✓ Excel 100

✓ Excel 200

✓ Excel 300



Feed the Grease Cup Holder (A6) through the hole in the Body (A5).

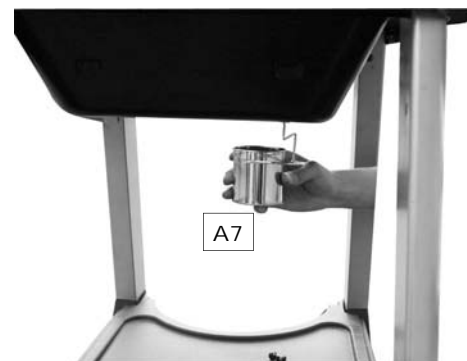

insert the Grease Cup (A7) into the Grease Cup Holder.

**11**

✓ Excel 100

✓ Excel 200

✓ Excel 300



Insert the main electrode (A12) into the hole at the bottom of the body and screw with the pre-assembled nut.

**12**

✓ Excel 100

✓ Excel 200

✓ Excel 300

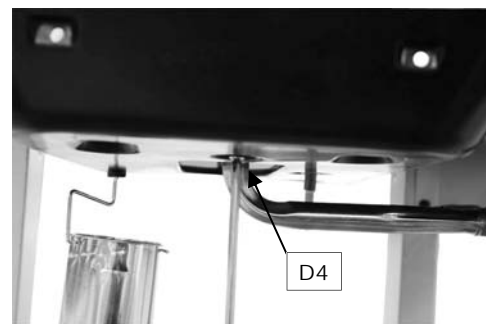
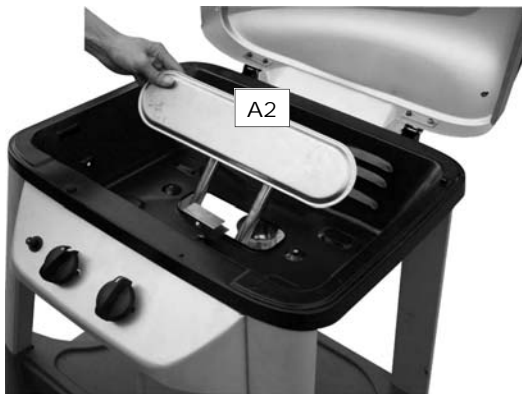

*View from underneath the body.*

Feed the Burner (A2) into the Body (A5) ensuring the burner venturi tubes are over the ends of the gas valves. They are a loose fit and not a gas tight seal. Secure the Burner with the Screws (D4).

13

✓ Excel 100

✓ Excel 200

✓ Excel 300



Attach the Heat Shield (A13) to the Body (A5) using the Screws (D2) and nuts (D7).

14

✓ Excel 100

✓ Excel 200

✓ Excel 300

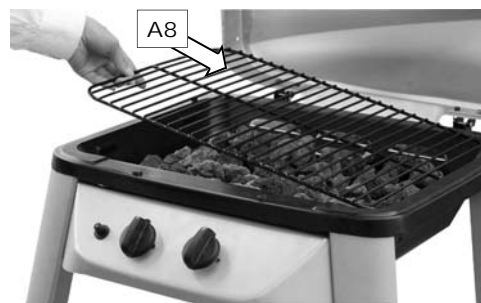
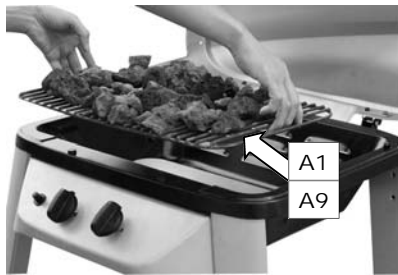

Place the Lava Rock Rack (A1) and Lava Rock (A9) into the body of the barbecue followed by the Cooking Grill (A8). Fit the Warming rack (A14). Make sure the swing legs fix to the body of the barbecue and the shorter, fixed legs go through the holes in the hood.

15

✓ Excel 100

✗ Excel 200

✗ Excel 300

Excel 200 and 300 users, skip this step and proceed directly to step 16.



Attach the Trolley Handle (B4) to the Long Legs using the screws (D1).

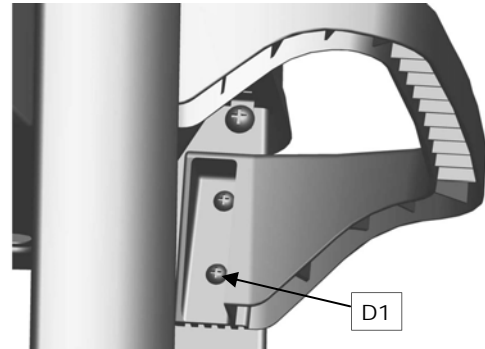

**EXCEL 100 USERS: ASSEMBLY IS NOW COMPLETE. Proceed to pages 19 onwards for operation and maintenance instructions.**  
**Important – the barbecue must not be used before being leak tested as detailed on P. 20**

16

✗ Excel 100

✓ Excel 200

✓ Excel 300

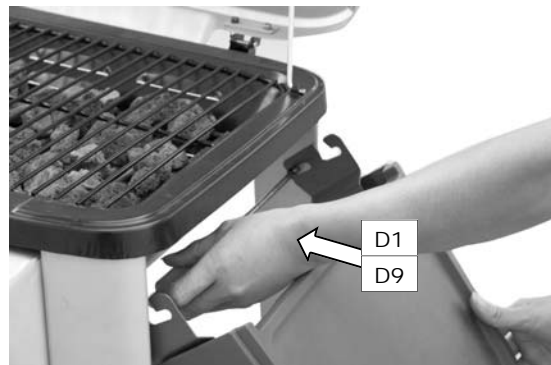

Attach a side shelf (B6) to the right hand side of the barbecue by sliding a shelf spacer (D9) onto a screw (D1) and fit the shelf to the lower fixing point on the rear leg as shown. Repeat for the front leg. Slide a shelf spacer (D9) onto a screw (D1) and screw it into the upper fixing point on the rear legs as shown. Repeat for the front leg.

**For Excel 200 only**, repeat the above procedure for the left hand side shelf.

**EXCEL 200 USERS: ASSEMBLY IS NOW COMPLETE. Proceed to pages 19 onwards for operation and maintenance instructions.**  
**Important – the barbecue must not be used before being leak tested as detailed on P. 20**



17

✗ Excel 100

✗ Excel 200

✓ Excel 300

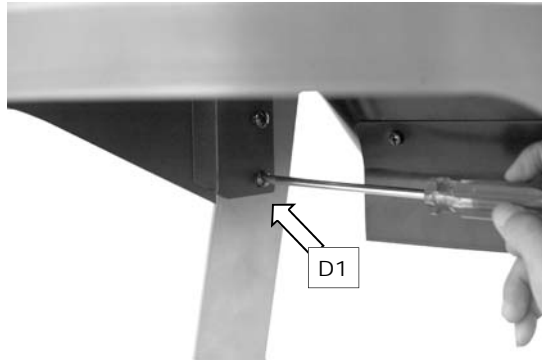

Attach the Side Burner Shelf (B9) to the Short Legs using the Screws (D1).

18

✗ Excel 100

✗ Excel 200

✓ Excel 300

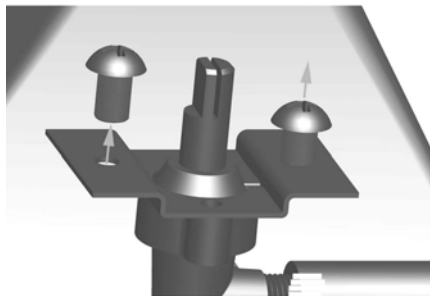

Remove the screws from Side Burner Valve/Hose Assembly (B12) and secure it to the side shelf with those 2 screws.

Assemble the Side Burner Knob (B7) onto the side burner valve.

19

✗ Excel 100

✗ Excel 200

✓ Excel 300



Place the Side Burner Electrode (B11) onto the side burner shelf as shown and place the Side Burner (B10) through the central hole and position the side burner venturi tube over the side burner gas valve. Secure the electrode and burner with Screw (D3). Note: The side burner venturi tube is a loose fit on the valve and not a gas tight seal.

20

✗ Excel 100

✗ Excel 200

✓ Excel 300



Connect the electrode wire to the Igniter Button (B2) under the control panel.



Side burner electrode wire goes here.

Main burner electrode wire goes here.

Place the Side Burner Grid (B8) onto the side burner shelf.



**ASSEMBLY IS NOW COMPLETE.**

Proceed to the next page for operation and maintenance instructions.  
Important – the barbecue must not be used before being leak tested as detailed on P. 20

## **E. Important Information**

**Please read these instructions carefully before assembly and use.**

- Retain these instructions for future reference.
- For outdoors use only – do not use indoors. Do not use below ground level.
- For use with LPG bottled gas only. A suitable regulator must be used for Butane, propane or mixes.
- Remove lava rock from plastic shrink pack before lighting.
- Do not use within 1m of any flammable structure or surface.
- LP gas cylinders should not be placed directly underneath the barbecue.
- LP gas cylinders must not be stored or used in the horizontal position. A leak would be very serious and liquid could enter the gas line.
- When igniting barbecue open its hood before lighting.
- Do not move the barbecue while alight.
- This barbecue must not be left unattended when lit.
- The hood handle can become very hot. Grip only the centre of the handle. Use of a cooking glove is advised.
- Use caution when opening the hood, as hot steam inside is released upon opening.
- Parts of this barbecue become very hot – care must be taken when children, elderly people, and animals are present.
- Always turn off the gas bottle when the barbecue is not in use.
- Never cover a barbecue until it has completely cooled.
- Never use the barbecue with the side shelf in the down position.
- Leak test annually, and whenever the gas bottle is removed or replaced.
- Do not store flammable materials near this barbecue.
- Do not use aerosols near this barbecue.
- Failure to follow the manual's instructions could result in serious injury or damage.
- Modification of the barbecue may be dangerous, is not permitted and will nullify any warranty.
- If you have any queries regarding these instructions, contact your local dealer.

## **F. Gas and Regulator**

This barbecue can use either propane or butane LPG bottled gas. Propane bottles, will supply gas all year round, even on cold winter days. A spanner may be required to change gas bottles. Butane bottles, will supply sufficient gas in summer, but performance of the barbecue may be affected once the gas temperature starts to fall below +10°C. The bottle should never be stood on the trolley base and placed directly under the barbecue. Gas bottles should never be stored or used laid on their side. Never store gas bottles indoors.

**YOU MUST HAVE THE PROPER REGULATOR AND BOTTLE IN ORDER FOR THE BARBECUE TO OPERATE SAFELY AND EFFICIENTLY. USE OF AN INCORRECT OR FAULTY REGULATOR IS DANGEROUS AND WILL INVALIDATE ANY WARRANTY.** Please consult your local gas dealer for the most suitable gas bottles and regulators.

## **G. Installation**

### **G1. Selecting a Location**

This barbecue is for outdoor use only and should be placed in a well-ventilated area. Take care to ensure that it is not placed UNDER any combustible surface. The sides of the barbecue should NEVER be closer than 1 metre from any combustible surface. Keep this barbecue away from any flammable materials!

### **G2. Precautions**

Do not obstruct any ventilation openings in the barbecue body. Secure the gas bottle on the cylinder holder and always tighten it with the black strap provided. Should you need to change the gas bottle, confirm that the barbecue is switched off, and that there are no sources of ignition (cigarettes, open flame, sparks, etc.) near before proceeding. Inspect the gas hose to ensure it is free of any twisting or tension. The hose should hang freely with no bends, folds, or kinks that could obstruct free flow of gas. Apart from the connection point, no part of the hose should touch any hot barbecue parts. Always inspect the hose for cuts, cracks, or excessive wear before use. If the hose is damaged, it must be replaced with hose suitable for use with LPG and meet the national standards for the country of use. The length of the hose shall not exceed 1.5m. *N.B.- The date on the orange hose (if supplied) is the date of manufacture, not the expiry date.*

### **G3. Connecting a Gas Hose to the Barbecue**

Connect the gas hose to the gas rail inlet on the left hand side of the barbecue. Do not overtighten. Do not use any sealing tape or liquid on the connection

### **G4. Fixing a Regulator to the Gas Bottle**

Confirm all barbecue control knobs are in the off position. Connect the regulator to the gas bottle according to your regulator and bottle dealer's instructions.

### **G5. Leak Testing (To be performed in a well-ventilated area.)**

Confirm all control knobs are in the off position. Open the gas control valve on the bottle or regulator. Check for leaks by brushing a solution of ½ water and ½ soap over all gas system joints, including all valve connections, hose connections and regulator connections. NEVER USE AN OPEN FLAME to test for leaks at anytime. If bubbles form over any of the joints, there is a leak. Turn off the gas supply and retighten all joints. Repeat test. If bubbles form again, do not use the barbecue. Please contact your local dealer for assistance. Leak test your barbecue annually. Check the hose connections are tight and leak test them each time you reconnect the gas bottle.

## **H. Operation**

### **H1. Warning**

- Before proceeding, make certain that you understand the **IMPORTANT INFORMATION** section of this manual.

### **H2. Preparation Before Cooking**

To prevent foods from sticking to the cooking grill, please use a long handled brush to apply a light coat of cooking or vegetable oil before each barbecuing session. **(Note: When cooking for the first time, paint colours may change slightly as a result. This is normal and should be expected.)**

### **H3. Lighting the Barbecue**

- Open the barbecue hood.
- Ensure all knobs are in the off position. Open the gas control valve on the gas bottle or regulator.
- Push and turn the leftmost control knob to the high position. Press the ignition button

rapidly several times until left portion of the burner is lit. If burner fails to ignite, turn control knob to the off position and turn gas off at the bottle or regulator. Wait five minutes, then repeat the above steps. After successful lighting of the left side, ignite the remaining portion of the burner. If the burner fails to ignite after following above procedure, turn all the knobs to the off position. Close the gas valve on the gas bottle. Wait 5 minutes, then repeat the above steps. If the barbecue still fails to light, please refer to the manual ignition instructions in section below.

- After ignition, the burner should be burned at the high position for 3-5 minutes in order to preheat the barbecue. This process should be done before every cooking session. The hood (where applicable) should be open during preheating.
- After completion of preheating, the burner should normally be turned down to a lower position for best cooking results.

### **H4. Manual Ignition Instructions**

- Open the barbecue hood.
- Insert lit match through the match-lighting hole on the right side of the barbecue.
- Push and turn the rightmost control knob anti-clockwise to the high position.
- After the right portion of the burner is lit, light the remaining portion of the burner.
- If burner fails to ignite, contact your local dealer for assistance.
- After ignition, the burner should be burned at the high position for 3-5 minutes in order to preheat the barbecue. This process should be done before every cooking session. The hood (where applicable) should be open during preheating.
- After completion of preheating, the burner should normally be turned down to a lower position for best cooking results.

### **H5. Grill Cooking**

The burner heats up the lava rock underneath the grill, which in turn heats the food on the grill. The natural food juices produced during cooking fall onto the hot lava rock below and vaporise. The subsequent rising smoke bastes the food, as it travels upwards, imparting that unique barbecued flavour. More even cooking of food will be achieved by using the barbecue with the hood down which will also hold the

heat in to aid cooking. This should only be done with the burners on a low to medium setting.

#### **H6. Roasting Hood Cooking**

Barbecues equipped with a roasting hood give the option of cooking with hood closed to form an 'oven' for roasting food, such as joints of meat, whole chickens, etc.

When roasting, turn the burner under the food to the OFF position. Close the hood and turn the other burner down to a lower setting i.e. low to medium to achieve the temperature required. **DO NOT ALLOW YOUR BARBECUE TO OVERHEAT.** Avoid lifting the hood unnecessarily as heat is lost each time the hood is opened.

#### **H7. Side-Burner Cooking**

When using the side-burner, care should be taken to ensure that pans are central and flat on the side-burner grid.

#### **H8. Flare-Up Control**

##### **\*\*\* Very Important Notice \*\*\***

Flare-ups occur when meat is barbecued, and its fat and juices fall upon the hot lava rock. Smoke of course helps give food its barbecued flavour, but it is best to avoid excessive flare-up to prevent food being burned. To control flare-ups, it is **ABSOLUTELY ESSENTIAL** to trim away excess fat from meat and poultry before grilling, use cooking sauces and marinades sparingly and try to avoid very cheap cuts of meat or meat products as these tend to have a high fat and water content. Also, the burners should always be placed on the low setting during cooking. When flare-ups do occur, they can usually be extinguished by applying baking soda or salt directly onto the lava rocks. Always protect your hands when handling anything near the cooking surface of the barbecue, and take care to protect yourself from the flames.

If a fat fire should occur, turn all knobs to the off position, turn off the gas at the bottle, and wait for the fire to go out. **NEVER** douse with water.

#### **H9. End of Cooking Session**

After each cooking session, turn the barbecue burner to the "high" position and burn for 5 minutes. This procedure will burn off cooking

residue, thus making cleaning easier. Make sure the hood is open during this process.

#### **H10. Turning Off Your Barbecue**

When you have finished using your barbecue, turn all the control valves fully clockwise to the "Off" position, then switch off the gas at the bottle. Wait until the barbecue is sufficiently cool before closing its hood.

## **I.CARE AND MAINTENANCE**

Regularly clean your barbecue between uses and especially after extended periods of storage. Ensure the barbecue and its components are sufficiently cool before cleaning. Do not leave the barbecue exposed to outside weather conditions or stored in damp, moist areas.

- Never douse the barbecue with water when its surfaces are hot.
- Never handle hot parts with unprotected hands.

In order to extend the life and maintain the condition of your barbecue, we strongly recommend that the unit be covered when left outside for any length of time, especially during the winter months. Heavy-duty Outback® barbecue covers and other accessories are available from your local Outback® stockist.

#### **I1. Cooking Grill**

Clean with hot soapy water. To remove any food residue, use a mild cream cleaner on a non-abrasive pad. Rinse well and dry thoroughly. We do not recommend cleaning grills in a dishwasher.

#### **I2. Burner Maintenance**

Your burner has been preset for optimal flame performance. You will normally see a blue flame, possibly with a small yellow tip when the burner is alight. If the flame pattern is significantly yellow, this could be a problem caused by grease from cooking blocking the burner or spiders or other insects in the burner venturi. This can result in the flow of the gas and air mixture being restricted or blocked which may result in a fire behind the control panel causing serious damage to your barbecue. **If this happens, the gas should be immediately turned off at the bottle.**

Burners should be inspected and cleaned on a regular basis in addition to the following conditions:

- 1) Bringing the barbecue out of storage.
- 2) One or more of the burners do not ignite.
- 3) The burner flame pattern is significantly yellow.
- 4) The gas ignites behind the control panel.

To clean a burner, remove it from the barbecue. The outside of the burner can be cleaned with a wire brush. Clean the portholes with a pipe cleaner or piece of wire. Take care not to enlarge the portholes.

Clean the insect screen on the end of the venturi tube with a bristle brush (i.e. an old toothbrush).

Clean the venturi tube with a pipe cleaner or piece of wire. You may need a torch to see into the venturi tube to make sure it is clear. "Turn the burner up on end and lightly tap against a piece of wood to dislodge any debris from inside."

### 13. Lava Rock

It is not necessary to remove and wash the lava rock in order to keep it clean. Burning off the residue after each cooking should be sufficient. Heavily impregnated lava rock should be turned over so that the dirty side faces the burners in order to burn off any residue. Replacement lava rock is available from your local Outback® stockist.

### 14. Barbecue Body

Regularly remove excess grease or fat from the barbecue body with a soft plastic or wooden scraper. It is not necessary to remove all the grease from the body. If you need to clean fully, use hot soapy water and a cloth, or nylon-bristled brush only. Remove cooking surfaces and burners before full cleaning. Do not immerse the gas controls or manifold in water. Check burner operation after carefully refitting into body.

### 15. Fixings

All screws and bolts, etc. should be checked and tightened on a regular basis.

### 16. Storage

Store your barbecue in a cool dry place. It must be inspected on a regular basis as damp or condensation can form which may result in damage to the barbecue. It may be necessary

to dry the barbecue and the inside of the cover if used. Mould can grow under these conditions and should be cleaned and treated if required. Any rust that is found that does not come into contact with the food should be treated with a rust inhibitor and painted with barbecue paint or a heat resistant paint. Chrome plated warming racks and grills should be coated with cooking oil. Wrap the burners in aluminium foil to help prevent insects or other debris from obstructing the burners. The gas bottle must be always be disconnected from the barbecue and stored in a well ventilated area at least 1 metre away from any fixed ignition source. Do not store inside residential accommodation. Never store cylinders below ground level (e.g. cellars). Do not let children tamper with bottles.

## J. Technical Specifications

	CE Approval	Heat Input	Burners	Injector Size	Gas / Pressure
<b>Outback® Excel 100</b>	0359 359BS791	6.2kW	1	0.89mm	Butane/ 28mbar Propane/ 37mbar
<b>Outback® Excel 200</b>	0359 359BS791	6.2kW	1		Butane/ Propane 30mbar
<b>Outback® Excel 300</b>	0359 359BS791	6.2kW	1		Butane/ Propane 50mbar
<b>Side Burner</b>	0359 359BS791	2.3kW	1	0.74mm	Butane/ Propane 50mbar
<b>Gas Consumption:</b> Excel 100: 446g/hr Excel 200: 446g/hr Excel 300: 446g/hr Side Burner: 165g/hr					
<b>Countries of Use:</b> I <sub>3+</sub> (28-30/37) BE, CY, CZ, EE, FR, GR, IE, IT, LV, LT, LU, PT, SK, ES, CH, GB, RO I <sub>3B/P(30)</sub> BG, CY, CZ, DK, EE, FI, GR, LV, LT, LU, MT, NL, NO, SK, SI, SE, TR, IS I <sub>3B/P(50)</sub> AT, DE, HU, SK, CH I <sub>3B/P(36)</sub> PL					

Specifications are subject to change without prior notice

## **K. Troubleshooting**

<b>Problem</b>	<b>Possible Cause</b>	<b>Solution</b>
<b>Burners will not light using the ignition system</b>	LP gas bottle is empty	Replace with full bottle
	Faulty regulator	Have regulator checked or replaced
	Obstructions in burners	Clean burners
	Obstructions in gas jets or gas hose	Clean jets and gas hose
	Electrode wire is loose or disconnected on electrode or ignition unit	Reconnect wire
	Electrode or wire is damaged	Change electrode and wire
<b>Burner will not light with a match</b>	Faulty pushbutton ignitor	Change ignitor
	LP gas bottle is empty	Replace with full bottle
	Faulty regulator	Have regulator checked or replaced
	Obstructions in burners	Clean burners
<b>Low flame or flashback (fire in burner tube— a hissing or roaring noise may be heard)</b>	Obstructions in gas jets or gas hose	Clean jets and gas hose
	LP gas bottle too small	Use larger bottle
	Obstructions in burners	Clean burners
	Obstructions in gas jets or gas hose	Clean jets and gas hose
	Windy conditions	Use BBQ in a more sheltered position
<b>Gas valve knob difficult to turn</b>	Gas valve jammed	Replace gas valve

For reference and correspondence, record your serial number here.  
(See sticker on side of barbecue body.)

**Serial No.** \_\_\_\_\_

This number may be required when ordering spare parts or accessories. A part reference number may also be required where applicable.

Published December 2007